

- **250 W AC-DC**
- **UP TO 88% EFFICIENCY**
- **HIGH POWER DENSITY:  
OVER 9 W / in<sup>3</sup>**
- **REMOTE ON / OFF**
- **10W 5V STANDBY SUPPLY**
- **UNIVERSAL AC INPUT**
- **ACTIVE PFC (90 – 264 VAC)**
- **BUILT IN OR'ING DIODES  
FOR N+1**
- **SMALL FOOTPRINT**
- **<1U HIGH: 1.5"**
- **INRUSH CURRENT  
PROTECTION**
- **RoHS COMPLIANT**

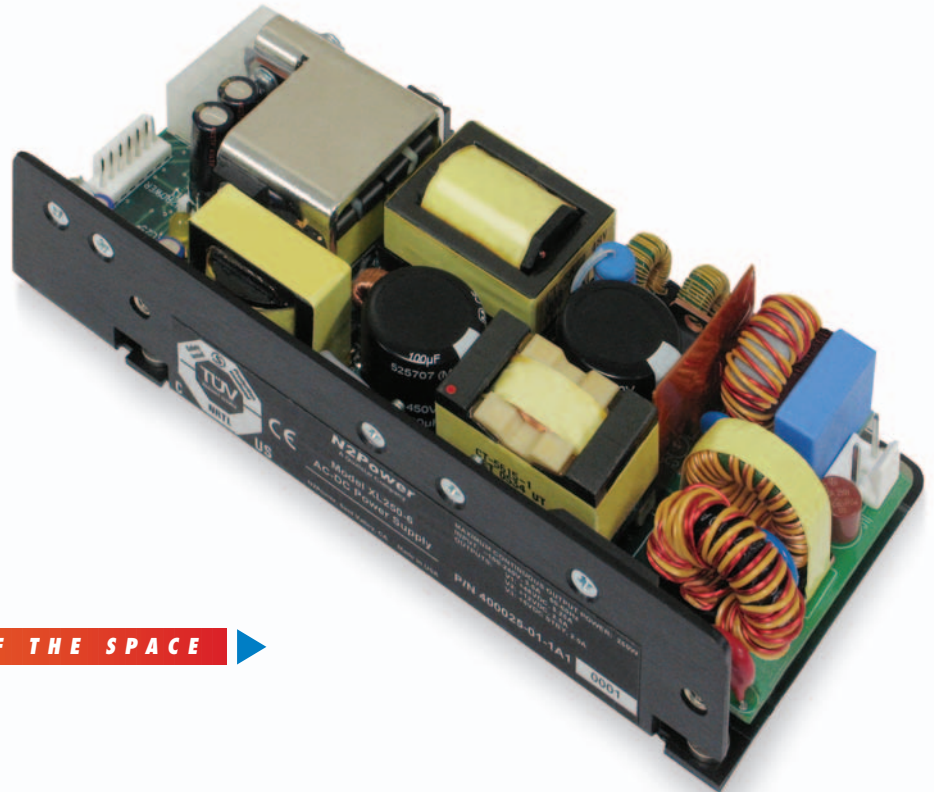

**POWER SUPPLY DESIGN LEADER**

N2Power leads the power density race with its latest small, high efficiency XL250 Series AC-DC power supplies.

**TWICE THE POWER IN HALF THE SPACE**

Our advanced technology yields a very small footprint, reduces wasted power, and offers the highest power density in the 250 watt class. This efficient design means reduced energy costs, a greater return on your investment, greater reliability and longer product life.

**UNMATCHED POWER DENSITY**

With an overall height of 1.5" and a 3" x 6" footprint, the XL250 Series boasts a power density over 9 watts per cubic inch. It is ideally suited for OEMs using the industry standard 1U chassis. The XL250's small form factor gives you additional "real estate" for more functionality inside your product. Increased space, reduced thermal loads and lower costs will increase your competitive edge in the market.

**HIGH EFFICIENCY IN A SMALL PACKAGE**

The XL250 Series provides up to 88% efficiency. Our unique design reduces energy consumption and generates less wasted heat. It requires little forced air cooling, decreases AC loading, increases reliability and economy of operation.

**Typical Mechanical Drawing:**

Connectors and pinouts may vary based on model.

Refer to XL250 engineering specifications for complete information.

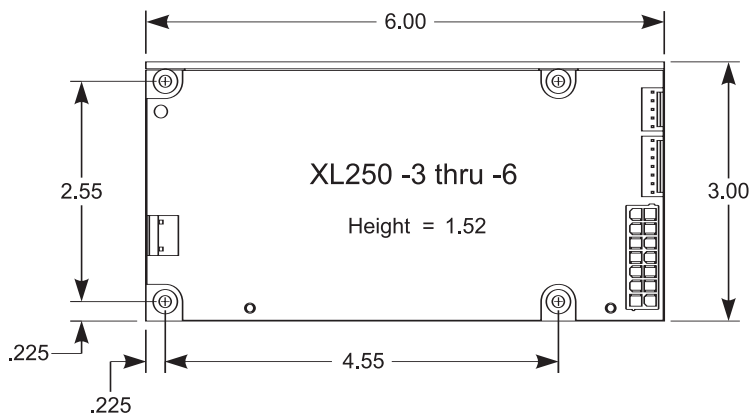

**PFC READY, SAVE ENERGY**

Many countries already require Power Factor Corrected (PFC) power supplies, which lessen loads at generating stations. All XL250 products incorporate active PFC technology

with universal input to provide superior efficiency. Comparisons of efficiencies show that our supplies can reduce losses up to 50%.

**REPEATABLE QUALITY**

We use advanced packaging technology to deliver the highest density and best performance in the industry. Our advanced SMT packaging design automates processes, ensures reliability, and reduces cost. Each power supply undergoes a complete functional test and a multi-hour burn-in to insure that every unit meets our stringent quality requirements. Detailed statistical production records are maintained and rigid quality and AVL control insures the highest quality product available. Each power supply design is rigorously tested by applicable agencies, with scheduled factory audits to ensure ongoing compliance.

All outputs except the standby 5-Volts can be turned on or off remotely.

Contact us regarding custom and modified standard supplies for unique applications.

MODEL	OUTPUT	VOLTAGE	REGULATION (%)	MAXIMUM CURRENT (A)	RIPPLE & NOISE (P-P)	DIMENSIONS W x L x D
XL250-3 +12VDC	V1*	12	±3	21.0	100 mV	3" x 6" x 1.5"
	V2	12	±5	2.5	80 mV	
	V3	5sb	±5	2.0	50 mV	
XL250-5 +24VDC	V1*	24	±3	10.5	100 mV	3" x 6" x 1.5"
	V2	12	±5	2.5	80 mV	
	V3	5sb	±5	2.0	50 mV	
XL250-6 +48VDC	V1*	48	±3	5.25	100 mV	3" x 6" x 1.5"
	V2	12	±5	2.5	80 mV	
	V3	5sb	±5	2.0	50 mV	

\* Isolated outputs for + / - use  
All outputs isolated from the chassis

INPUT SPECIFICATIONS	
Nominal Input Voltage:	100 - 240 VAC
Tested Input Limits:	90 - 264 VAC
Input Frequency Range:	47 - 63 Hz
Input Current:	3.5 A @ 100 VAC
Input Protection:	5 A fuse
Safety Isolation:	3000 VAC input to output 1500 VAC input to ground
Inrush Current:	12 A @ 240 VAC†
Power Factor Correction:	active PFC circuitry, meets or exceeds EN61000-3-2

OUTPUT SPECIFICATIONS	
Power:	250 W
Hold-up Time:	minimum 22 mS at all input voltages
Efficiency:	up to 88%†
Minimum Load:	no load†
Over / Under Shoot:	maximum 10% at turn-on
PROTECTION	
Overvoltage Protection:	on all main outputs (latch off)
Overpower Protection:	protected / auto recovery
Short Circuit Protection:	auto recovery of all outputs protected against short circuit
Thermal Shutdown:	auto recovery protection against over temperature conditions

OPERATING SPECIFICATIONS	
Operating Temperature:	-25°C to +50°C
Temperature Derating:	2.5% / degree 50°C to 70°C
Storage Temperature:	-40°C to +85°C
Forced Air Cooling:	10 CFM minimum†
Leakage Current:	< 1.5 mA†
MTBF:	> 200,000 hours calculated
SIGNALS	
Remote Sense:	on main output†
Current Sharing:	active wire with or'ing diode†
Power Good:	high-true output†
PS_OK:	low-true output†
PS_ON:	open = off, low = on†
LEDs:	AC_ON and PS_OK†

† See Engineering Specification

**COMPLIANCE:**

**USA/Canada:**

UL60950 / C22.2, 60950 (Bi-National Standard) Safety of Information Technology Equipment

**Europe:**

73/23/EEC "Low Voltage Directive" (Safety)  
IEC 60950-1 (2001) Safety of Information Technology Equipment. CB certificate and report available.  
EN60950 (2000) Safety of Information Technology Equipment  
89/336/EEC "Electromagnetic Compatibility Directive" (EMC)  
EN61000-3-3 (1995) Limits of Voltage Fluctuations & Flicker  
EN61000-3-2 (2000) Harmonic Current Emissions (Power Factor Correction)  
EN61204-3 (2001) Stabilized Power Supplies, d.c. Outputs  
EMC Standards Specification EN61204 (2001) is a product family EMC standard which references the following specifications:  
EN61000-4-2 (1995) ESD  
EN61000-4-3 (1996) +A1 (1998) Radiated Radio Frequency.  
Electromagnetic Field Immunity  
EN61000-4-4 (1995) Fast Transient / Burst Immunity

EN61000-4-5 (1995) Surge Immunity  
EN61000-4-6 (1996) Immunity to Conducted Disturbances  
EN61000-4-11 (1994) Voltage Dips, Short Interrupts & Voltage Variations

Safety Approvals: TÜV, CE Mark  
Emissions: FCC Class B



For complete specifications on all models, please visit our website at: [www.N2Power.com](http://www.N2Power.com)

**N2Power**  
A Qualstar Company  
3990-B Heritage Oak Court  
Simi Valley, CA 93063  
NASDAQ: QBAK

Fax: 805-583-7749  
Tel: 805-583-7744  
800-468-0680 (U.S. Toll Free)  
E-mail: [sales@N2Power.com](mailto:sales@N2Power.com)  
Website: [www.N2Power.com](http://www.N2Power.com)

All information and specifications are based on our knowledge of the products at the time of printing. N2Power reserves the right to change specifications without notice.

Qualstar and the Qualstar logo are registered trademarks of Qualstar Corporation. All other trademarks are the property of their respective owners.

Copyright © 2006 • Qualstar Corporation.  
All rights reserved. Printed in USA.  
NDS014 3/06